

# SG 1020

---

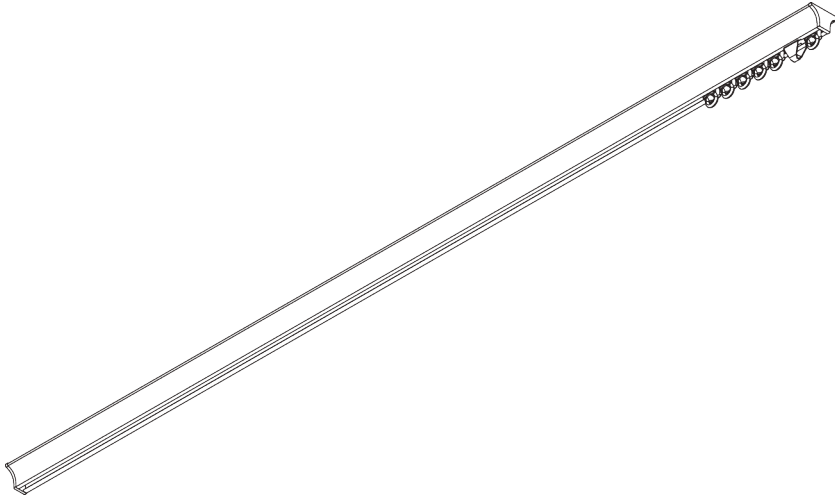
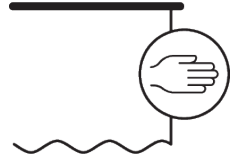

## PRODUCT INFORMATION

- **Operation:** hand
- **Range:** S
- **Fitting:** ceiling
- **Colours:** white RAL 9016; special colours or anodised aluminum possible
- **Fabrics:** refer to Silent Gliss fabric collection

### **Features:**

- Symmetrical funnel design
- Bendable

# SYSTEM SPECIFICATIONS

## A. SYSTEM DIMENSIONS

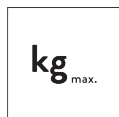

10 kg

## B. PROFILE

Profile and bending information

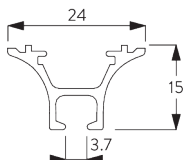

**SG 6822**

Profile Funnel

Radius:  
✓ >27 cm

## C. HOW TO MEASURE

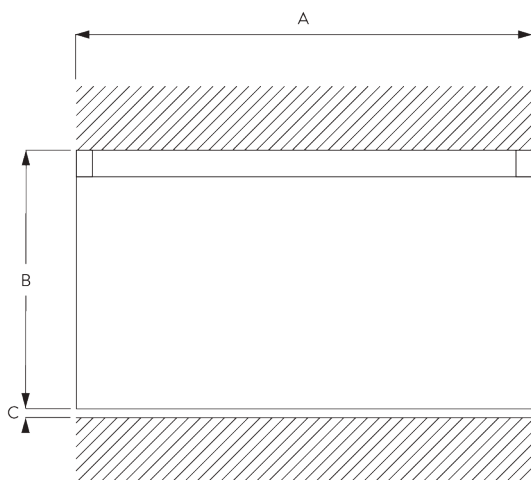

A: System width

B: System height

C: Distance between floor and fabric

## D. SPECIFICATION TEXT

**Silent Gliss SG 1020 Hand Operated Curtain Track System.** Comprises aluminium profile SG 6822 supplied made to measure powder coated white, with gliders SG 3533 at 14/m and 2 end covers SG 6824 and 2 end stops SG 3016 per length. Top fixed with clip brackets SG 11236 at max. 500 mm centres.

# FITTING

## A. FITTING INFORMATION

For detailed fitting information, visit the *Silent Gliss* website.

### Fixing points

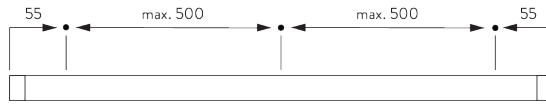

### Fitting Tool

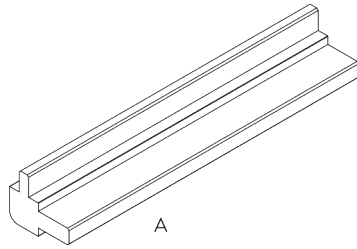

A: Funnel fitting tool SG 6827

For fitting / removing of the funnel profile.

## B. CEILING FITTING

### Clip SG 11236

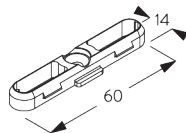
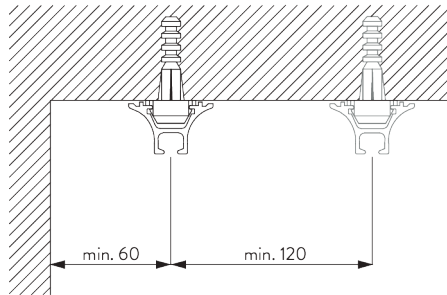

SG 11236

Clip

# GENERAL NOTES

## **Dimensions**

- Measurements are in mm except where indicated.
- Max. kg relates to fabric incl. accessories.
- Stack size depends on curtain make-up and fabric thickness.
- Distance between gliders max. 80 mm / distance between rollers max. 100 mm.
- Recommended distance floor / fabric: 20 mm.
- In order to determine system height (B), the smallest room height must be taken into account.

## **Fitting**





- Installation by qualified fitter only.
- Number of brackets and fitting positions / fixing points vary depending on fitting surface, system weight, fabric make-up, screw / fixing type and obstacles.
- Qualified fitter must use appropriate screws / fixings for each situation.
- Profile lip if applicable to be installed to room side.

## **Child Safety**

- All relevant Silent Gliss systems correspond to child safety EN 13120.
- All parties involved must comply with EN 13120.

# PARTS

## A. STANDARD PARTS

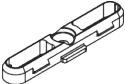
	<b>SG 3016</b> End stop
	<b>SG 3533</b> Glider
	<b>SG 6822</b> Profile Funnel
	<b>SG 6824</b> End cover
	<b>SG 11236</b> Clip

## B. OPTIONAL PARTS

	<b>SG 3062</b> Connection bridge
	<b>SG 3070</b> End stop
	<b>SG 3071</b> End stop
	<b>SG 3511</b> Glider
	<b>SG 3534</b> Glider 3533 on strip
	<b>SG 3548</b> Glider
	<b>SG 3570</b> Glider
	<b>SG 3582</b> Hook
	<b>SG 3599</b> Hook
	<b>SG 10430</b> Draw rod 50 cm
	<b>SG 10431</b> Draw rod 75 cm
	<b>SG 10432</b> Draw rod 100 cm
	<b>SG 10433</b> Draw rod 125 cm
	<b>SG 10434</b> Draw rod 150 cm

	<b>SG 11335</b> End stop
---	-----------------------------





